

Polymer PTC Resettable Fuse: KRL Series



Radial Leded Type For Line Voltage Application

■ Features

1. RoHS & Halogen-Free (HF) compliant
2. Radial leaded devices
3. Hold current ratings from 0.05A ~ 3A
4. Maximum operating voltage: 120Vac, 240Vac
5. Operating & storage temperature range : -40 ~ +85°C
6. Agency Approval: UL / cUL / TUV

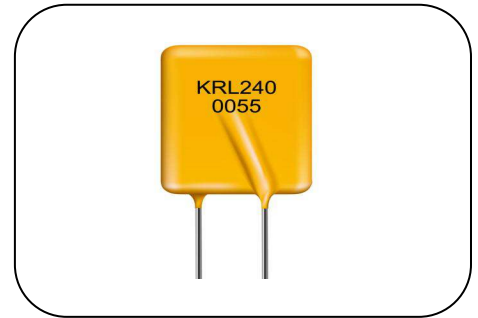

■ Recommended Applications

1. Motors
2. Transformers
3. Power supplies
4. Industrial controllers
5. Home appliance

■ Part Number Code

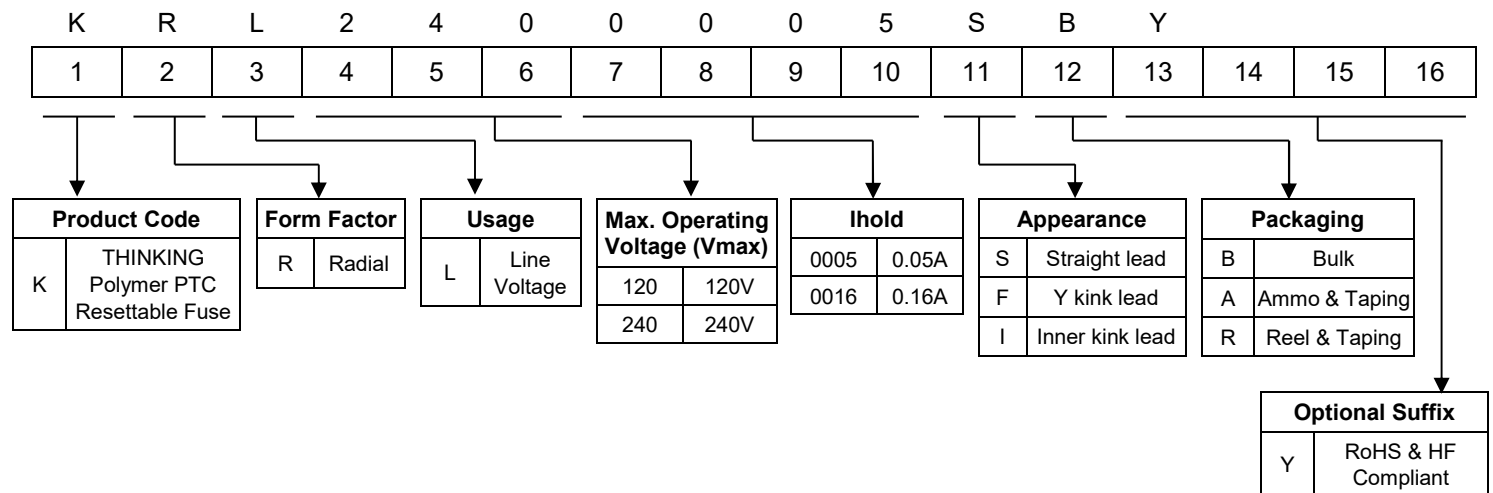

Polymer PTC Resettable Fuse: KRL Series



Radial Leded Type For Line Voltage Application

Structure and Dimensions

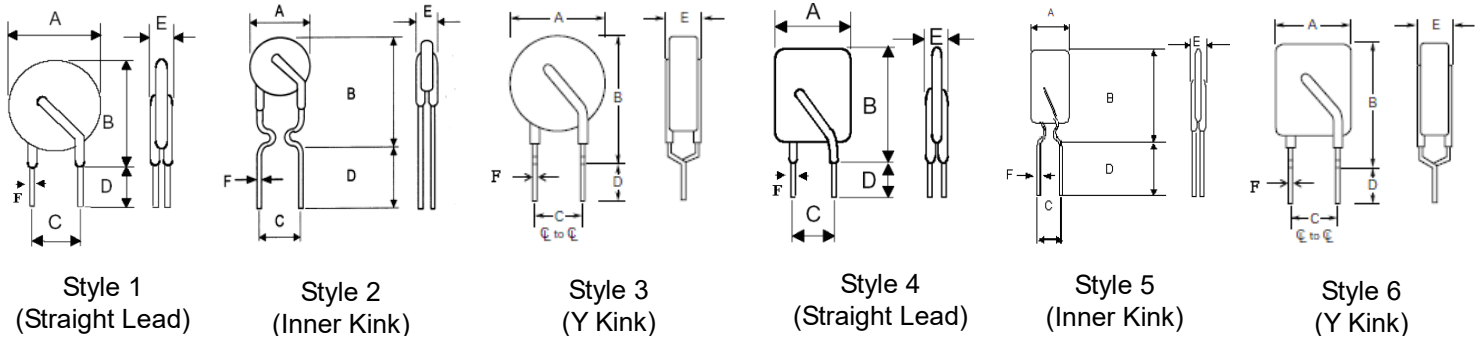

Marking: Device is marked with product type, Vmax, and I hold.

(Unit: mm)

Part No.	A		B				C		D		E		F		Figure
	Min.	Max.	F Kink/ Inner Kink		Straight Lead		Min.	Max.	Min.	Max.	Min.	Max.	Min.	Max.	Style
			Min.	Max.	Min.	Max.									
KRL1200005	6.8	8.3	10.9	12.1	6.7	10.7	4.2	5.8	7.6	11.6	2.6	4.6	0.48	0.52	1,2,3
KRL1200008	6.8	8.3	10.9	12.4	6.7	10.7	4.2	5.8	7.6	11.6	2.6	4.6	0.48	0.52	1,2,3
KRL1200012	6.8	8.3	10.9	12.9	6.7	10.7	4.2	5.8	7.6	11.6	2.6	3.8	0.48	0.52	1,2,3
KRL1200016	7.7	9	11.8	13.8	7.6	12.3	4.2	5.8	7.6	11.6	2.6	3.8	0.48	0.52	1,2,3
KRL1200025	7.9	9.5	16	18	11.8	16.5	4.2	5.8	7.6	11.6	2.6	3.8	0.58	0.62	1,2,3
KRL1200033	9	10.6	16	18	11.8	16.5	4.2	5.8	7.6	11.6	2.6	3.8	0.58	0.62	4,5,6
KRL1200040	9.9	11.5	18	20	13.8	18.5	4.2	5.8	7.6	11.6	2.6	3.8	0.58	0.62	1,2,3
KRL1200055	10.9	12.5	18	20	13.8	18.5	4.2	5.8	7.6	11.6	3	4.1	0.78	0.82	4,5,6
KRL1200075	9.9	10.9	13.8	18	17	20	4.2	5.8	7.6	11.6	3	4.1	0.78	0.82	4,5,6
KRL1200200	18.2	19.1	25.3	27.3	21.1	25.8	9.2	10.8	7.6	11.6	3	5.1	0.78	0.82	4,5,6
KRL1200300	25.8	28.4	29.9	31.9	25.7	30.4	9.2	10.8	7.6	11.6	3	5.1	0.78	0.82	1,2,3
KRL2400005	6.8	8.3	10.9	12.1	6.7	10.7	4.2	5.8	7.6	11.6	2.6	4.6	0.48	0.52	1,2,3
KRL2400008	6.8	8.3	10.9	12.4	6.7	10.7	4.2	5.8	7.6	11.6	2.6	4.6	0.48	0.52	1,2,3
KRL2400012	6.8	8.3	10.9	12.9	6.7	10.7	4.2	5.8	7.6	11.6	2.6	3.8	0.48	0.52	1,2,3
KRL2400016	7.7	9.0	11.8	13.8	7.6	12.3	4.2	5.8	7.6	11.6	2.6	3.8	0.48	0.52	1,2,3
KRL2400025	7.9	9.5	16	18	11.8	16.5	4.2	5.8	7.6	11.6	2.6	3.8	0.58	0.62	4,5,6
KRL2400033	9	10.6	16	18	11.8	16.5	4.2	5.8	7.6	11.6	2.6	3.8	0.58	0.62	4,5,6
KRL2400040	9.9	11.5	18	20	13.8	18.5	4.2	5.8	7.6	11.6	2.6	3.8	0.58	0.62	4,5,6
KRL2400055	10.9	12.5	18	20	13.8	18.5	4.2	5.8	7.6	11.6	3	4.1	0.78	0.82	4,5,6
KRL2400075	9.9	11.5	18	20	13.8	18.5	4.2	5.8	7.6	11.6	3	4.8	0.78	0.82	4,5,6
KRL2400100	16.4	18	20.5	22.5	16.3	21	9.2	10.8	7.6	11.6	3	5.1	0.78	0.82	1,2,3
KRL2400125	18.4	20	22.5	24.5	18.3	23	9.2	10.8	7.6	11.6	3	5.3	0.78	0.82	1,2,3
KRL2400135	15.6	16.3	23.5	25.5	19.3	24	4.2	5.8	7.6	11.6	3	4.1	0.78	0.82	4,5,6
KRL2400200	22.4	24	26.5	28.5	22.3	27	9.2	10.8	7.6	11.6	3	6.1	0.78	0.82	4,5,6

Polymer PTC Resettable Fuse: KRL Series



Radial Leaded Type For Line Voltage Application

■ Electrical Characteristics at 23°C

Part No.	V _{max.}	V _{interrupt}	I _{max.}	I _{hold}	I _{trip}	P _d (Typ.)	Max. Time to Trip		Resistance		Safety Approvals	
	(V _{ac})	(V _{ac})	(A)	(A)	(A)	(W)	Current (A)	Time (Sec.)	Initial R _i Min. (Ω)	Post Trip R ₁ Max. (Ω)	UL/ cUL	TUV
	KRL1200005	120	135	20	0.05	0.12	0.9	0.25	15	18.5	65	√
KRL1200008	120	135	20	0.08	0.19	0.9	0.4	15	7.4	26	√	√
KRL1200012	120	135	20	0.12	0.3	1	0.6	15	3	12	√	√
KRL1200016	120	135	20	0.16	0.37	1.4	0.8	15	2.5	7.8	√	√
KRL1200025	120	135	20	0.25	0.56	1.5	1.25	18.5	1.3	3.8	√	√
KRL1200033	120	135	20	0.33	0.74	1.7	1.65	21	0.77	2.6	√	√
KRL1200040	120	135	20	0.4	0.9	2	2	24	0.6	1.9	√	√
KRL1200055	120	135	20	0.55	1.25	3.4	2.75	26	0.45	1.45	√	√
KRL1200075	0.75	1.5	120	135	7.5	2.64	3.75	15	0.25	0.69		√
KRL1200200	120	135	20	2	4.2	4.3	10	36	0.08	0.21	√	√
KRL1200300	120	135	20	3	6	4.5	15	19.8	0.04	0.1	√	√
KRL2400005	240	265	1	0.05	0.12	0.7	0.25	15	18.5	65	√	√
KRL2400008	240	265	1.2	0.08	0.19	0.8	0.4	15	7.4	26	√	√
KRL2400012	240	265	1.2	0.12	0.30	1	0.6	15	3	12	√	√
KRL2400016	240	265	2	0.16	0.37	1.4	0.8	15	2.5	7.8	√	√
KRL2400025	240	265	3.5	0.25	0.56	1.5	1.25	18.5	1.3	3.8	√	√
KRL2400033	240	265	4.5	0.33	0.74	1.7	1.65	21	0.77	2.6	√	√
KRL2400040	240	265	5.5	0.40	0.9	2	2	24	0.6	1.9	√	√
KRL2400055	240	265	7	0.55	1.25	3.4	2.75	26	0.45	1.45	√	√
KRL2400075	240	265	7.5	0.75	1.5	2.6	3.75	18	0.25	0.84	√	√
KRL2400100	240	265	10	1	2	2.9	5	21	0.179	0.58	√	√
KRL2400125	240	265	12.5	1.25	2.5	3.3	6.25	23	0.117	0.44	√	√
KRL2400135	240	265	13.5	1.35	2.7	4	6.75	20	0.109	0.3	√	√
KRL2400200	240	265	20	2	4	4.5	10	36	0.075	0.22	√	√

Note: UL&cUL File No: E138827

TUV File No: R50279312

Polymer PTC Resettable Fuse: KRL Series



Radial Leaded Type For Line Voltage Application

■ Typical Time to Trip Curves at 23°C

KRL1200005~KRL1200300

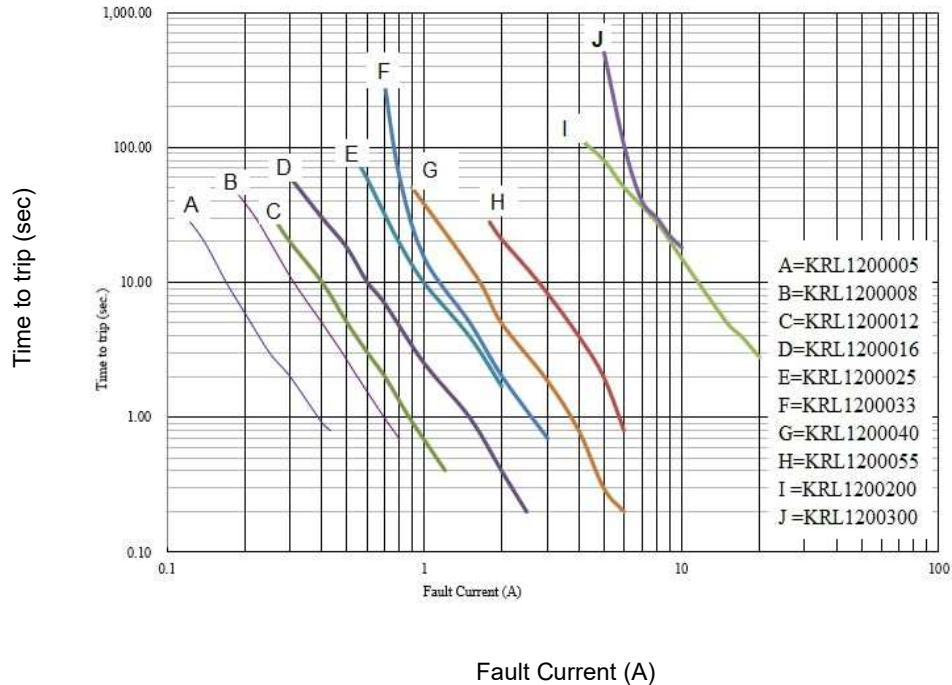

KRL2400005~KRL2400200

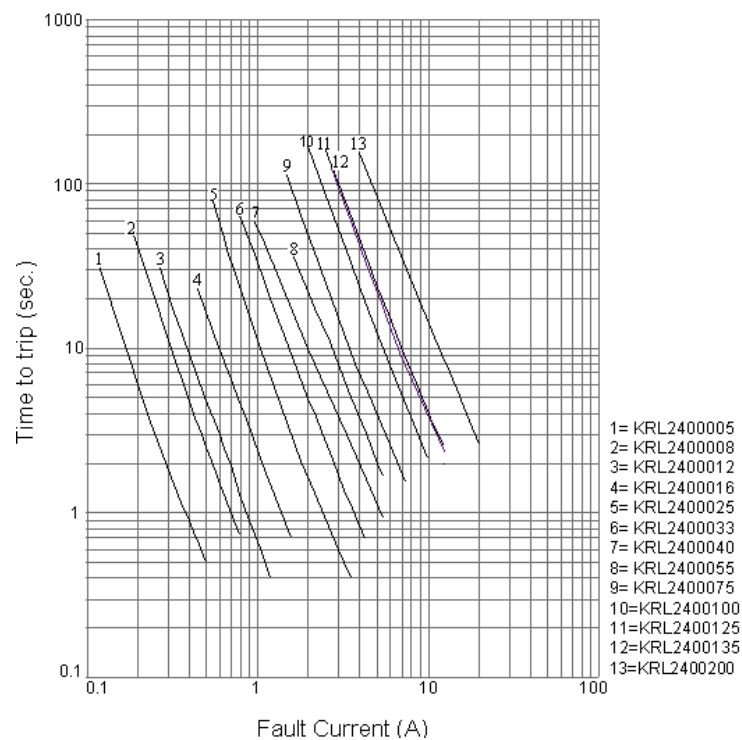



■ Ihold & Itrip Thermal Derating Curve

Derating Curve for KRL120 Series

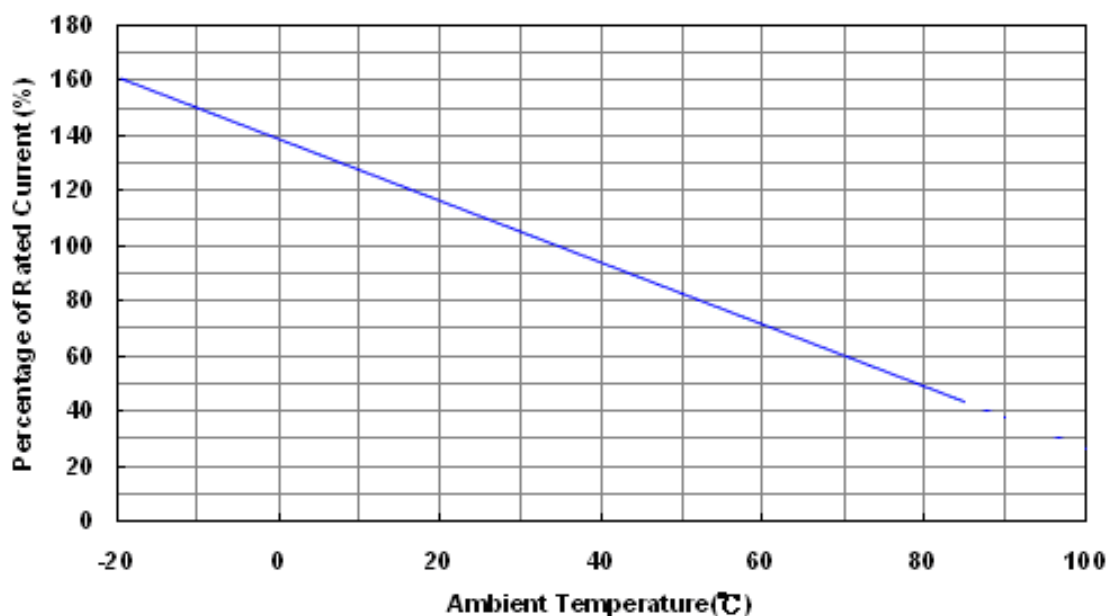

■ Ihold Thermal Derating Chart

(Unit: A)

Part no	Ambient Temperature								
	-40°C	-20°C	0°C	23°C	40°C	50°C	60°C	70°C	85°C
KRL1200005	0.08	0.07	0.06	0.05	0.04	0.04	0.03	0.03	0.02
KRL1200008	0.128	0.11	0.1	0.08	0.07	0.06	0.05	0.04	0.03
KRL1200012	0.192	0.16	0.15	0.12	0.1	0.09	0.07	0.06	0.04
KRL1200016	0.256	0.21	0.2	0.16	0.13	0.11	0.1	0.08	0.05
KRL1200025	0.4	0.34	0.32	0.25	0.21	0.18	0.15	0.13	0.09
KRL1200033	0.528	0.44	0.42	0.33	0.27	0.23	0.2	0.17	0.11
KRL1200040	0.64	0.54	0.51	0.4	0.33	0.28	0.24	0.2	0.14
KRL1200055	0.88	0.74	0.68	0.55	0.46	0.4	0.35	0.29	0.22
KRL1200075	1.19	1.04	0.89	0.75	0.60	0.53	0.45	0.38	0.29
KRL1200200	3.2	2.68	2.4	2	1.8	1.6	1.4	1.2	0.85
KRL1200300	4.8	4.02	3.6	3	2.7	2.4	2.1	1.8	1.2

Polymer PTC Resettable Fuse: KRL Series



Radial Leded Type For Line Voltage Application

■ Ihold & Itrip Thermal Derating Curve

Derating Curve for KRL240 Series

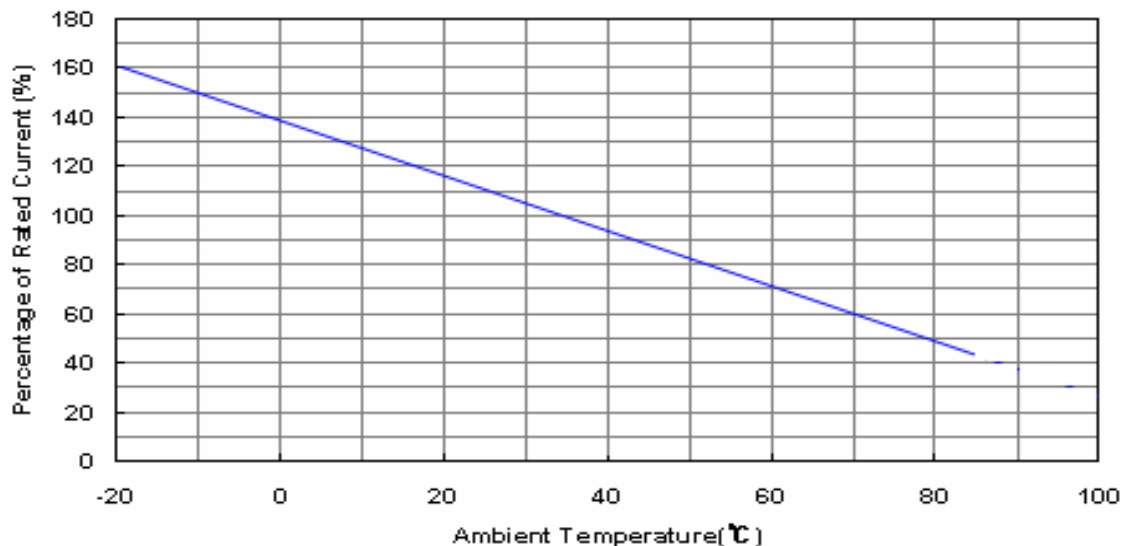

■ Ihold Thermal Derating Chart

(Unit: A)

Part no	Ambient Temperature								
	-40°C	-20°C	0°C	23°C	40°C	50°C	60°C	70°C	85°C
KRL2400005	0.08	0.07	0.06	0.05	0.04	0.04	0.03	0.03	0.02
KRL2400008	0.128	0.11	0.1	0.08	0.07	0.06	0.05	0.04	0.03
KRL2400012	0.192	0.16	0.15	0.12	0.1	0.09	0.07	0.06	0.04
KRL2400016	0.256	0.21	0.2	0.16	0.13	0.11	0.1	0.08	0.05
KRL2400025	0.4	0.34	0.32	0.25	0.21	0.18	0.15	0.13	0.09
KRL2400033	0.528	0.44	0.42	0.33	0.27	0.23	0.2	0.17	0.11
KRL2400040	0.64	0.54	0.51	0.4	0.33	0.28	0.24	0.2	0.14
KRL2400055	0.88	0.74	0.68	0.55	0.46	0.4	0.35	0.29	0.22
KRL2400075	1.2	1.01	0.98	0.75	0.6	0.56	0.49	0.45	0.41
KRL2400100	1.6	1.34	1.3	1	0.8	0.75	0.65	0.6	0.55
KRL2400125	2	1.68	1.63	1.25	1	0.94	0.81	0.75	0.69
KRL2400135	2.16	1.81	1.65	1.35	1.12	1.01	0.9	0.78	0.65
KRL2400200	3.2	2.68	2.6	2	1.6	1.5	1.3	1.2	1.10

Polymer PTC Resettable Fuse: KRL Series



Radial Leaded Type For Line Voltage Application

■ Reliability

Item	Standard	Test Condition/methods	Criteria
Resistance to Soldering Heat	IEC 60068-2-58	260 ± 5°C, 10±1 sec	Rf<R1max, No visible damage
Passive Aging	IEC 60738-1	85±5°C, 1000±24hrs	±5% typical resistance change
Humidity Aging	IEC 60068-2-78	85±5°C, 80~85%RH, 1000±5hrs	±5% typical resistance change
Rapid Change of Temperature	IEC 60738-1	85±5/-40±5°C, 10 cycles, Duration: 30min	±5% typical resistance change
Overload Endurance	UL 1434	Vmax, 120% Imax, 50 cycles Vmax, 300% Itrip, 6000 cycles	No visible damage
Trip Endurance	UL 1434	Vmax, Itrip ≤ I ≤ Imax, 1000±24hrs	No visible damage

■ Packaging

Devices are taped according to IEC 60286-2 standards. See table below and Fig. 1~5 for details.

Description	EIA Mark	Dimensions (mm)	Tolerance (mm)
Sprocket hole pitch	P ₀	12.70	±0.3
Ordinate to adjacent component lead KRL1200005-KRL1200055, KRL2400005~KRL2400075, KRL2400135	P ₁	3.85	±0.7
Ordinate to adjacent component lead KRL2400100, KRL2400125, KRL2400200		7.7	±0.7
Device pitch KRL1200005-KRL1200040, KRL2400005-KRL2400040, KRL2400075	P	12.70	±1.0
Device pitch KRL1200055-KRL1200200, KRL2400055, KRL2400135, KRL2400100, KRL2400125, KRL2400200		25.40	
Device pitch KRL1200300		38.1	
Carrier tape width	W	18.00	+1/-0.5
Top distance between tape edges	W ₂	3.00	Max
Hold-down tape width	W ₀	12.00	±1.5
Sprocket hole position	W ₁	9.00	+0.75/-0.5
Lead spacing KRL1200005-KRL1200055, KRL2400005-KRL2400075, KRL2400135	C	5.0	±0.8
Lead spacing KRL1200200-KRL1200300, KRL240100, KRL2400125, KRL2400200		10.0	
Lead diameter KRL1200005-KRL1200016, KRL2400005~KRL2400016	d	0.50	±0.02
Lead diameter KRL1200025-KRL1200040, KRL2400025~KRL2400040		0.60	
Lead diameter KRL1200055-KRL1200300, KRL2400055~KRL2400200		0.80	
Abscissa to top KRL1200005-KRL1200016, KRL2400005-KRL2400016	H ₁	32.20	Max
Abscissa to top KRL1200025-KRL1200300, KRL2400025-KRL2400200		47.50	
Abscissa to plane (straight lead)	H	18.00	+2/-0
Abscissa to plane (Y kinked lead)	H ₀	16.00	±0.5
Sprocket hole diameter	D ₀	4.00	±0.2
Lead protrusion	L ₁	0.50	Max
Tape thickness	t	0.60	±0.2
Body tape plane deviation	Δh	2.00	Max.
Body lateral deviation	Δp	1.00	Max.
Reel width	W3	See reel specification	±1
Reel diameter		340.00	±10.0
Arbor hold diameter	n0	31.00	±1
Core diameter	n	80.00	Min.

Polymer PTC Resettable Fuse: KRL Series



Radial Leded Type For Line Voltage Application

● Taping Specification (KRL120 Series)

Fig.1 For KRL1200005 ~ KRL1200016

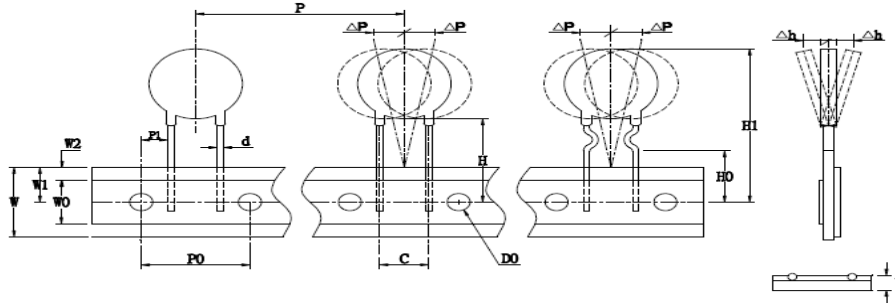

Fig.2 For KRL1200025 ~ KRL1200075, KRL1200200

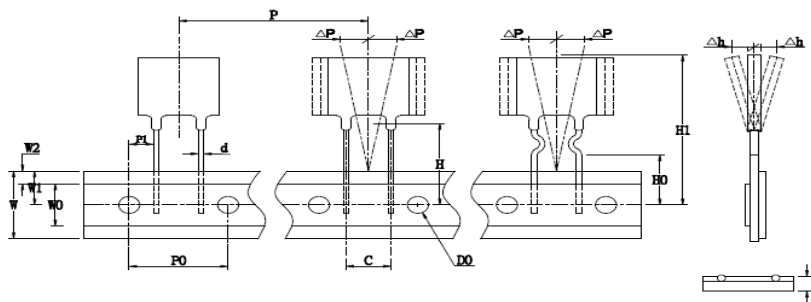
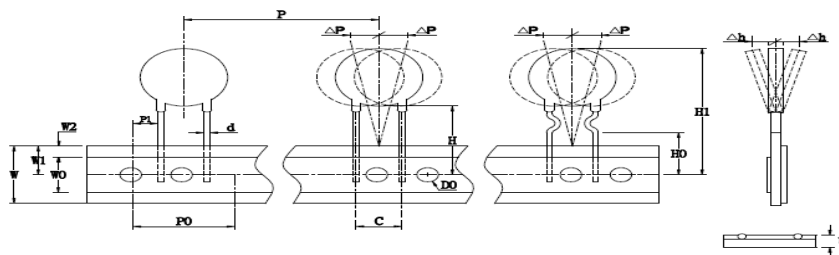

Fig.3 For KRL1200300



Part Number	P_0 ± 0.3	P ± 1	P_1 ± 0.7	W $+0.1/-0.5$	W_0 ± 1.5	W_1 $+0.75/-0.5$	W_2 Max.	C ± 0.8	H_1 Max.	H $+2/-0$ (straight lead)	H_0 ± 0.5 (Y kink lead)	W_2 Max.	D_0 ± 0.2	L_1 Max.	t ± 0.2	Δp Max.	Δh Max.	d ± 0.2
KRL1200005	12.7	12.7	3.85	18	12	9	3	5	32.2	18	16	3	4	0.5	0.6	1	2	0.5
KRL1200008		12.7	3.85					5	32.2									0.5
KRL1200012		12.7	3.85					5	32.2									0.5
KRL1200016		12.7	3.85					5	32.2									0.5
KRL1200025		12.7	3.85					5	47.5									1
KRL1200033		12.7	3.85					5	47.5									1
KRL1200040		12.7	3.85					5	47.5									1
KRL1200055		25.4	3.85					5	47.5									0.8
KRL1200075		25.4	3.85					5	47.5									0.8
KRL1200200		25.4						10	47.5									0.8
KRL1200300	38.1		10	47.5	0.8													

Polymer PTC Resettable Fuse: KRL Series



Radial Led Type For Line Voltage Application

● Taping Specification (KRL240 Series)

Fig .1 For KRL2400005 ~ KRL2400016

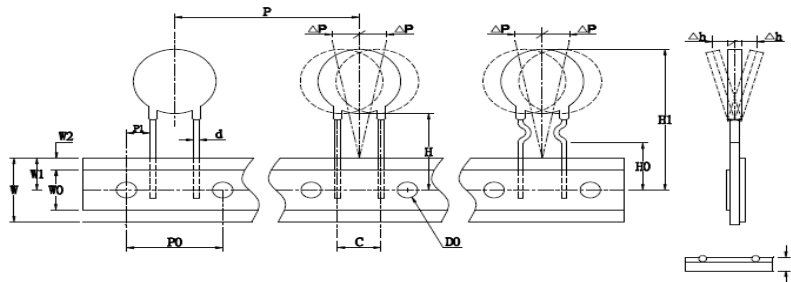

Fig. 2 For KRL2400025 - KRL2400055, KRL2400075, KRL2400135

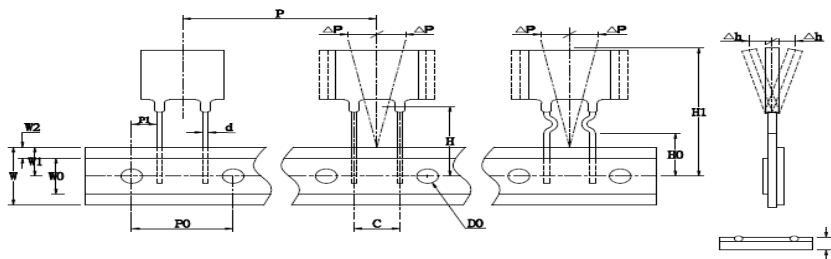

Fig. 3 For KRL240100 and KRL2400125

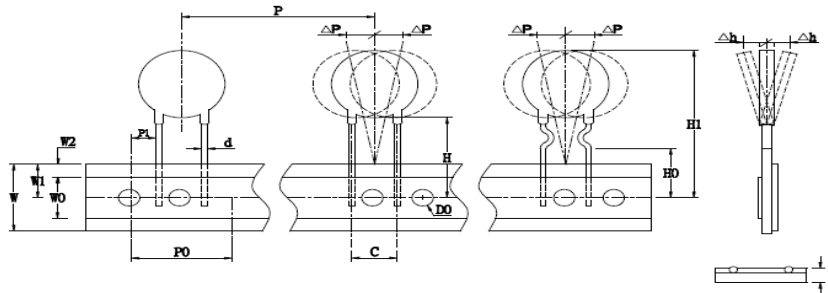
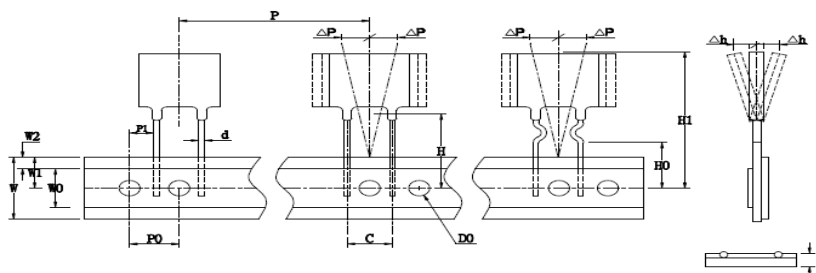

Fig. 4 For KRL2400200



Part Number	P ₀ ±0.3	P ±1	P ₁ ±0.7	W +0.1/ -0.5	W ₀ ±1.5	W ₁ +0.75/ -0.5	W ₂ Max.	C ±0.8	H ₁ Max.	H +2/-0 (Straight lead)	H ±0.5 (Y kink lead)	W ₂ Max.	D ₀ ±0.2	L ₁ Max.	t ±0.2	Δp Max.	Δh Max.	d ±0.2
KRL2400005	12.7	12.7	3.85	18	12	9	3	5	32.2	18	16	3	4	0.5	0.6	1	2	0.5
KRL2400008		12.7	3.85					5	32.2									0.5
KRL2400012		12.7	3.85					5	32.2									0.5
KRL2400016		12.7	3.85					5	32.2									0.5
KRL2400025		12.7	3.85					5	47.5									1
KRL2400033		12.7	3.85	5	47.5	1												
KRL2400040		12.7	3.85	5	47.5	0.8												
KRL2400055		25.4	3.85	5	47.5	0.8												
KRL2400075		12.7	3.85	5	47.5	0.8												
KRL2400100		25.4	7.7	10	47.5	0.8												
KRL2400125		25.4	7.7	10	47.5	0.8												
KRL2400135		25.4	3.85	5	47.5	0.8												
KRL2400200		25.4	7.7	10	47.5	0.8												

Polymer PTC Resettable Fuse: KRL Series



Radial Leded Type For Line Voltage Application

● Reel Specification

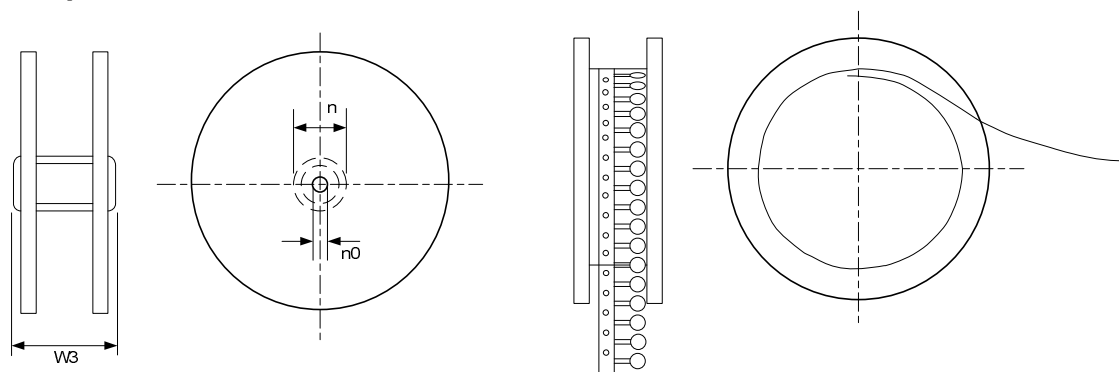

Series	W3 (mm)
KRL1200005~KRL1200075, KRL2400005~KRL2400100	46±1
KRL1200200, KRL2400125, KRL2400135, KRL2400200	52±1
KRL1200300	55±1

■ Quantity

● Bulk Packing

Series	Quantity (pcs/bag)
KRL1200005~KRL1200055, KRL1200075, KRL2400005~KRL2400075	500
KRL1200200, KRL1200300	200
KRL2400100~KRL2400200	250

● Reel Packing

Series	Quantity (pcs/reel)
KRL1200055, KRL1200200, KRL1200300, KRL2400055, KRL2400100, KRL2400125~ KRL2400200	1,000
KRL1200025~KRL1200040, KRL1200075, KRL2400025~KRL2400040, KRL2400075	1,500
KRL1200005~KRL1200016, KRL2400005~KRL2400016	2,000

Polymer PTC Resettable Fuse: KRL Series

Radial Leaded Type For Line Voltage Application



● Ammo Packing

Series	Quantity (pcs/box)
KRL1200005~KRL1200016, KRL2400005~KRL2400016	1,000
KRL1200025~KRL1200300, KRL2400025~KRL2400200	500

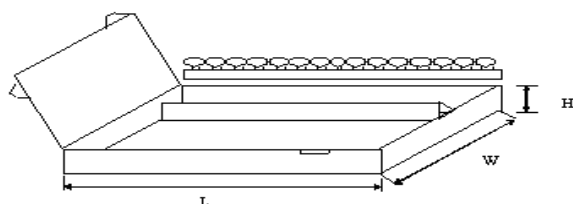

(Unit: mm)

Series	W	L	H
KRL1200005~KRL1200300	345	275	55
KRL2400005~KRL2400200			

■ Warehouse Storage Conditions of Products

● Storage Conditions :

1. Storage Temperature: $-10^{\circ}\text{C} \sim +40^{\circ}\text{C}$
2. Relative humidity: $\leq 75\% \text{RH}$
3. Thermistors must be kept away from sunlight and stored in a non-corrosive atmosphere.

● Period of Storage: 1 year